

## Installation recommendations

Thank you for purchasing hardWALL internal lining board. hardWALL is a natural timber wall lining that offers a very unique industrial look that will transform the identity of a space, creating a raw modern atmosphere. hardWALL is a high feature product characterised by naturally occurring and manmade features.

hardWALL can be fixed to existing walls and ceilings (that are level and in good condition) as well as wall framing, battens, rafters or joists.

### General Tools required.

- Power Saw
- Elastomeric adhesive
- Spirit Level
- Brad Gun & C1 32mm brads – or similar

### 1. Plan

- Measure up the area and verify the coverage provided per board. Calculate the minimum amount needed to cover the area and then add a minimum 10% for wastage for installation on a solid backed wall or 20% for installation over battens or studs for both horizontal and vertical hardWALL application.
- The maximum spacing of battens or studs is 450mm centres.

### 2. Handling

- hardWALL should be stored in a dry, waterproof, and well protected area, which is similar to the location it's going to be installed in.

### 3. Preparation

- Any plasterboard wall where hardWALL is going to be installed must be flat and clean.
- Ensure wall is square.
- Ensure the wall or ceiling has no signs of moisture ingress.

### 4. Installation – Horizontal boards

- Start at the bottom of the wall and with the tongue facing up. Position the board using 10mm wedges along the bottom and a 5mm wedge at each end to leave an expansion gap. This will be covered by the skirting board or trim installed at the end. Make sure this first row is straight & level.
- Using an elastomeric adhesive apply a bead in a tight "S" pattern on the back of the board when installing on a plasterboard wall/ ceiling. For installation to the battens / stud apply a bead down each batten / stud. Note. Only ever spread enough glue to allow a maximum of 30 minutes work ahead.
- Using a C1 32mm brad\* or similar, nail @ 45° through the top edge of the tongue at a maximum 450mm centres, into the stud or batten.

### T&G Secret Nailing

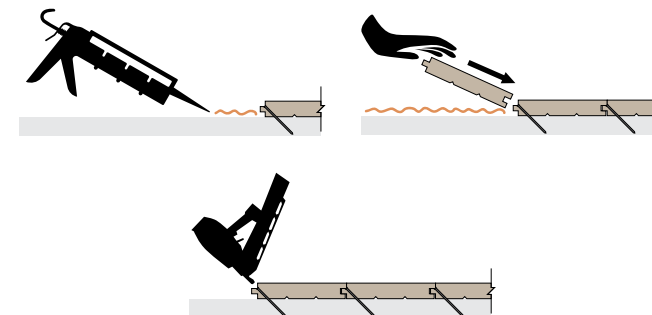

- Continue installing up the wall, applying adhesive to the back of the boards (or to each batten or stud) and nailing at each batten or stud. Ensuring nail fixing goes into the batten or stud.
- It is advised to check with a spirit level every 3 or 4 rows to ensure the installation is remaining straight and level. Small corrections are easier to correct this way than trying to fix at the end.
- When you reach the top, the last board may need to be ripped with a power saw to fit – again, ensure you leave a 10mm expansion gap.
- Additional expansion allowance is required in walls greater than 3m in height. In humid locations extra expansion & or acclimatisation will be required.

### 5. Installation – Vertical boards

- Glue & fasten a 42x35mm seasoned timber batten horizontally with a 75mm nail into studwork. Battens should be a maximum of 450mm centres.
- Measure the width of the wall and calculate the width of the ripped board required to finish. (Note. allow 10mm expansion at each end) Divide this by 2 to get 2 evenly sized rows to start and end your installation (Note. One row will require a tongue & one row will require a groove).

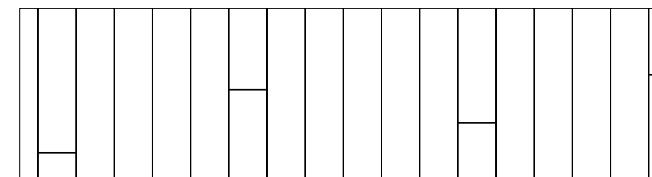

Example: Measurement of the wall width	3000mm
Less (-) total expansion gaps (10mm both sizes)	20mm
Equals	= 2980mm
Divide (+) hardWALL board width	130mm
Equals total quantity of board width rows (22 rows plus .92 of a one row)	= 22.92
Find out the board width for .92	
Times (x) the hardWALL board width by .92	= 119.60mm
Divide (+) by 2	= 59.8mm

59.8mm will be the width size of the start and end board you will need to cut too (Note. One row will require a tongue (Starter board) & one row will require a groove (end board). By not doing this equation and starting with a full size board your end board may be a variable width and not uniform across the wall. A look you may not be happy with.

- c. Starting from one side of the wall with your cut board with tongue facing out, position the board using 10mm wedges along the edge of the wall to leave an expansion gap and a 5mm wedge at the ceiling and floor for expansion. This will be covered by a trim. Make sure this first row is straight & level.
- d. Apply a bead of elastomeric adhesive along each batten. Note. Only ever spread enough glue to allow a maximum of 30 minutes work ahead.
- e. Using a C1 32mm brad\* or similar, nail @ 45° through the top edge of the tongue at a maximum 450mm centres, into the batten.

#### T&G Secret Nailing

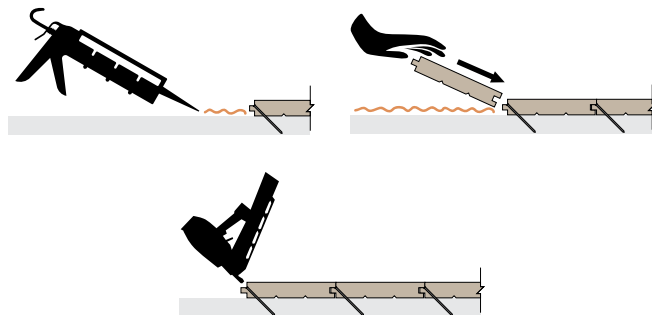

- f. Continue across the wall, ensuring adhesive coverage and nailing into each batten.
- g. It is advised to check with a spirit level every 3 or 4 rows to ensure the installation is remaining straight and level. Small corrections are easier to correct this way than trying to fix at the end.
- h. When you reach the opposite side utilise the ripped boards with a groove to finish your installing ensuring you have left a 10mm expansion gap.
- i. Additional expansion allowance is required in walls greater than 3m wide. In humid locations extra expansion & or acclimatisation will be required.

#### 6. Trim

- a. Finish the wall by adding a Trim or Skirting board to the edges, bottom & top, this will ensure the 10mm expansion gap is covered.
- b. Any exposed ends can be finished with a square timber trim or 14mm aluminium strip.

#### 7. Sealing

- a. Apply a suitable internal timber finish, such as a penetrating oil or hardwax oil, on your new hardWALL to help protect the timber and make it shine.

#### Product Specification

Species	Lights – Blackbutt, Tallowood, Grey Box Reds – Blue Gum , Red Iron Bark Darks – Brush Box, Spotted Gum, Grey Iron Bark
Seasoning	Kiln Dried
Size	130mm x 14mm, 180mm x 14mm
Profile	Square Edged Tongue & Grooved End Matched
Face	Highly featured – manmade and naturally occurred
Grade	Conservation - Making the most out of the precious resource Conservation grade focuses on the highest amount of natural and manmade features. This unique product gives a true industrial appearance.
Length	Random
Note	hardWALL is recommended as an internal wall lining only. Not suitable as a flooring product



**QUALITY TIMBER PRODUCTS**

[www.hurfordwholesale.com.au](http://www.hurfordwholesale.com.au)